



DMS
International

THE BEST CHOICE

for a green future



IT // EN



in the sign of tannery.

DMS
RCPaint
Double Print

DMS
RC Paint
Double Print

**MACCHINA
BREVETTATA
// PATENTED**



THE BEST CHOICE
for a green future

Larghezza utile di lavoro:
1800 - 2200 - 2400 mm
// Usable working width:
1800 - 2200 - 2400 mm

Lama Racla ad inserimento
lineare e pneumatico
// Squeegee Blade linear
and pneumatic insertion

Adatto a tutti
i tipi di pelle
// Suitable for
all leather types

Sistema bloccaggio
introduttore pelle
// Locking system
introducer leather

RC Double Print è l'innovativa macchina a rullo per l'applicazione di effetti a disegno su pelli, tessuti, carta e materiali sintetici.

A rendere unica **RC Double Print** è la possibilità di stampare sulla stessa pelle

con un solo passaggio, due disegni diversi anche con colore differente, sovrapponendoli in modo personalizzato.

Larghezza utile di lavoro disponibile: **1800 - 2200 - 2400 mm.**

RC Double Print is the innovative roll coating machine for applying effects to leather, fabrics, paper and synthetic materials.

What makes **RC Double Print** unique is that it can superimpose two

different patterns - even using different colours - on the same leather in a personalised manner, all in just one pass.

Available effective working widths: **1800 - 2200 - 2400 mm.**



Porte scorrevoli per una agevole manutenzione
// Sliding doors for easy maintenance

Pannello comandi analogici con touch screen
// Analog control panel with touch screen

Macchina facilmente mobile su rotaia
// Easily move machine along the rails

« RC Double Print, la sintesi perfetta tra tecnologia, semplicità e sostenibilità ecologica.

RC Double Print, the perfect blend of technology, simplicity and ecological sustainability. »

Tappeto di trasporto // Conveyor belt

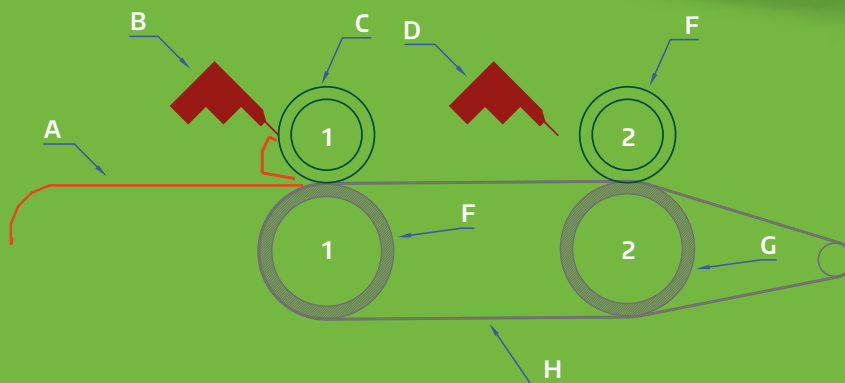

- A Banco // Bench
- B Lama Racla "Syncro" 1 // Doctor Blade "Syncro" 1
- C Cilindro Inciso 1 // Engraved Cylinder 1
- D Lama Racla "Syncro" 2 // Doctor Blade "Syncro" 2
- E Cilindro Inciso 2 // Engraved Cylinder 2
- F Rullo Gommato 1 // Rubber Cylinder 1
- G Rullo Gommato 2 // Rubber Cylinder 2
- H Tappeto di trasporto // Belt

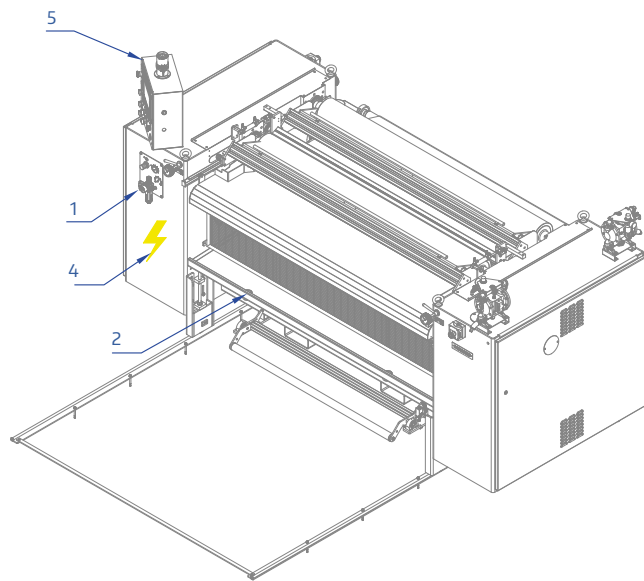
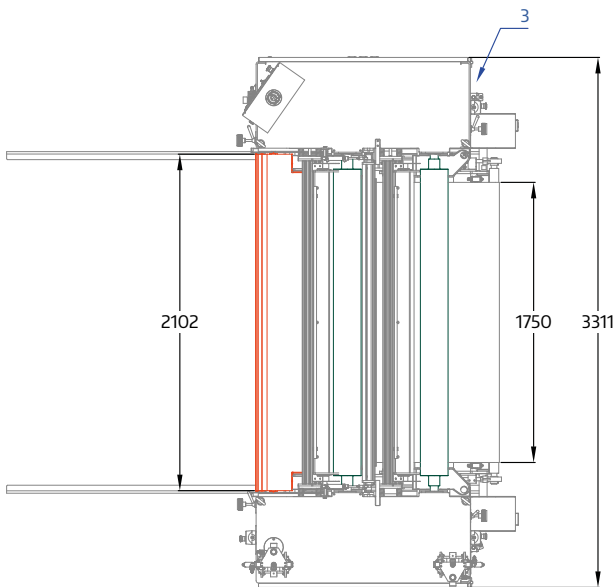
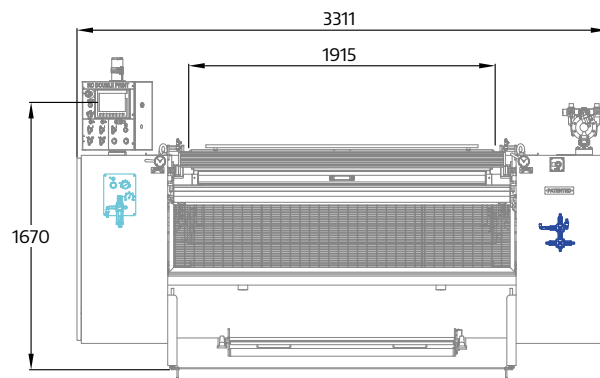
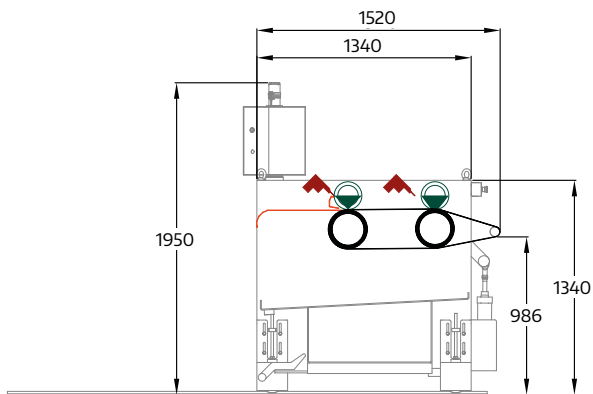

LARGHEZZA DI LAVORO // WORKING WIDTH	A	B	C	D	PESO MACCHINA // WEIGHT MACHINE	POTENZA INSTALLATA // INSTALLED POWER
1800	1915	3311	1750	2102	2600 kg	3,3 kW
2200	2315	3711	2150	2502	2950 kg	
2400	2515	3911	2350	2702	3100 kg	

- 1 Attacco aria compressa Ø 1/4" - 7 bar**
 // Air connection, Ø 1/4" - 7 bar
- 2 Scarico Ø 1" 1/2 tubo Ø 50 mm**
 // Hydraulic drain Ø 1" 1/2 - tube Ø 50 mm
- 3 Entrata connessione elettrica**
 // Electrical connection entry
- 4 Quadro elettrico a bordo macchina**
 // General electrical panel on-board
- 5 Pannello comandi**
 // Control panel

Chi siamo // About us

Dietro l'innovativo progetto **RC Paint** c'è **DMS International**, realtà nata nel 2017 come costola di **DMS Italia** per rispondere alla continua richiesta di un macchinario innovativo e performante, conta un team di 14 professionisti motivati e forti di una lunga esperienza nel settore.

// Behind the innovative project **RC Paint** there **DMS International**, company founded in 2017 as an offshoot of **DMS Italy** to meet the continuous demand of an innovative and powerful machine, has a team of 14 professionals motivated and armed with a long experience in the field.

Perchè sceglierci // Why choose us



Esperienza ed affidabilità

// Experience and reliability



Completa conoscenza del mercato e soluzione precisa alle problematiche tecniche più comuni

// Complete knowledge of the market and accurate solution to the technical problems common



Efficiente servizi di post vendita e garanzia di assistenza continuativa

// Efficient after-sales service and guarantee of continuous assistance



DMS International

Via E. De Nicola, 21
36075 Montecchio Maggiore (VI) - Italy

T. +39 0444 451080
info@dmsinternational.it



dmsinternational.it